

DAMPA®

Marine Ceiling Systems



Technical Information

DAMPA DCC 300/200

Suspended, Fire Rated Marine Ceiling System

Contents

Product Description	3
Ceiling Panels	3
Certificates and Approvals	4
Sound Insulation	4
Sound Absorption	4
Air Injection	4
Installation Principles	5
Installation of Suspension Components	6
Shock Test	6
Installation of Ceiling Panels	7
Demounting of Ceiling Panels	7
Calculation of Ceiling Panel Lengths	7
Perimeter Details	8
Change in Ceiling Direction	8
Downstands	8
Jointing	9
Factory Modified Panels	10
Adaptor Panels	11
Speaker Grilles	11
Inspection/Access Panels	11
DAMPA Luminaires	12
DAMPA Top Profiles	12
Modular Pre-Planning Concept	12
Colours and Surfaces	12
Standard Packing	13
Marking and Labelling Concept	13
Fast Reliable Delivery	13
Quality Assurance	13
References	13
Engineering Expertise	13
Basic Installation Components	14
Optional Installation Components	14
Edge Trims and Joining Profiles	14
Accessories	15
Top/Bottom Profiles	15

Product Description

The DAMPA DCC 300/200 System is a Fire Rated, Suspended Marine Ceiling System consisting of linear ceiling panels in two modular widths, 300 mm and 200 mm. The same carrier type is used for both widths. Fast and efficient installation is assured, as ceiling panels are supplied 'pre-cut' in

accordance with customer drawings and specifications. By use of only a few basic components a functional and aesthetically pleasing ceiling can be designed to suit all types of areas. Fast and reliable delivery is a trademark of DAMPA's modern and flexible production facilities.

Ceiling Panels

The DCC 300/200 Ceiling Panels are made from stove-enamelled 0.6/0.5 mm galvanised steel respectively.

The panels can be supplied perforated or plain, and in any specified length, from 600 to 5000 mm as standard.

Lengths less than 600, and up to 6000 mm can be made to order.

All panels are 26 mm deep and are supplied with end closings and 25 mm mineral wool inlay as standard.

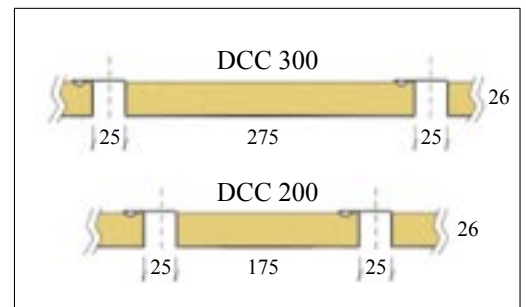

The following types are available:

Type 308/208

Plain surface with inlay of 25 mm mineral wool.

Weight: 6.7/6.2 kg/sq.m.

Fire classification: B-0, A-15.

With additional insulation overlay:

Weight: Approx. 8.9/8.4 kg/sq.m.

Fire classification: B-15, A-30, A-60.

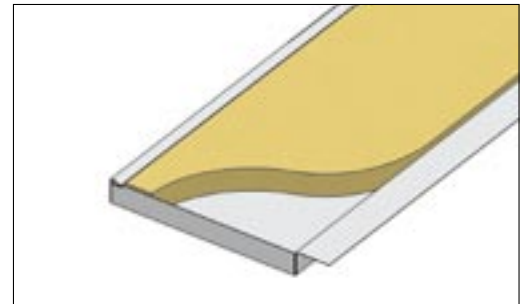

Type 315/215

Perforated with 1.8 mm holes at 3.5 mm centres (20.5%), and with black acoustic left bonded to the reverse side.

Inlay of 25 mm mineral wool.

Weight: 5.8/5.6 kg/sq.m.

Fire classification: B-0, A-15.

With additional insulation overlay:

Weight: Approx. 8.0/7.8 kg/sq.m.

Fire classification: B-15, A-60.

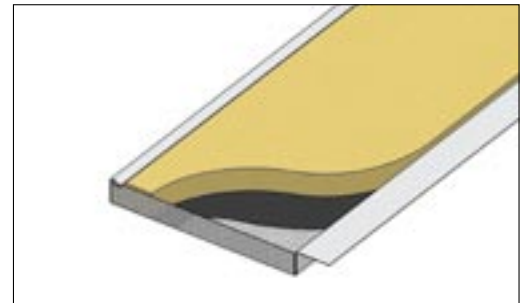

Type 310/210

Plain with air injection slots.

Same basic characteristics as type 308/208, plus 2 rows of 3 x 7 mm air injection slots at 15 mm centres (air inlet area equal to 0.0028 sq.m./lin.m ceiling panel).

Inlay of 25 mm mineral wool in PE-sleeves.

Weight: 6.7/6.2 kg/sq.m.

Fire classification: C.

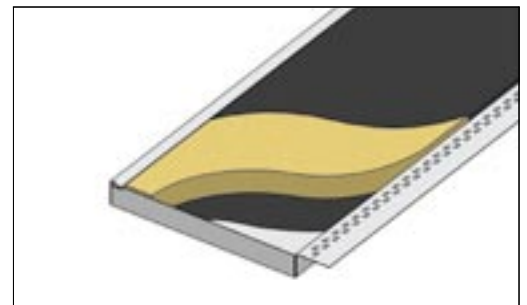

Type 313/213

Perforated with air injection slots.

Same basic characteristics as type 315/215.

Air injection slots as type 310/210.

Inlay of 25 mm mineral wool in PE-sleeves.

Weight: 5.7/5.6 kg/sq.m.

Fire classification: C.

Note: The suspension system, based on average consumption rate, weighs 1.5 kg/sq.m.

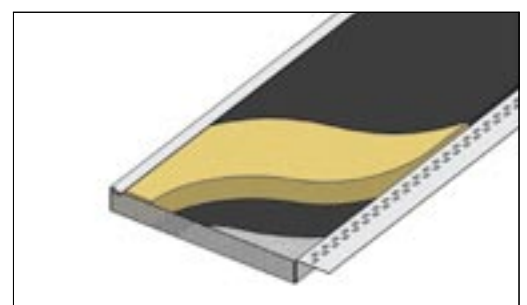

Certificates and Approvals

IMO and SOLAS Requirements

The DAMPA DCC 300/200 Ceiling System has been tested in accordance with the latest IMO and SOLAS requirements regarding resistance to fire, flame spread and toxicity.

Non-Toxicity and Calorific Value

The stove-enamelled surface of the DAMPA DCC ceiling panels has passed the IMO non-toxicity test and the calorific value is proved to be less than 1 MJ/sq.m.

CE-mark of Conformity, etc.

The ceiling system fulfils the EEA Marine Equipment Directive 96/98 EC and is thus qualified to use the CE-Mark of Conformity and additionally certified by leading national authorities and classification societies worldwide.

To ensure compliance with your specific project-related requirements, please contact DAMPA.



Sound Insulation

Room-to-room sound reduction of 41 dB - 44 dB depending on type of insulation inlay, and from 46 dB - 50 dB depending on type of additional insulation overlay.

These figures are the results of tests on DCC 300 Plain, by an independent test institute.



Sound Absorption

To reduce the general sound level and reverberation time within a room the perforated DCC Panels can be used effectively for sound absorption.

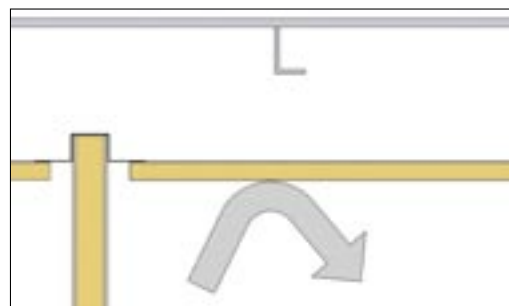

Air Injection

DCC Panels with air injection slots give an even distribution of air. A ventilation solution which is both elegant and cost-effective in C-class areas where the ceiling void is used as an air supply chamber. (See panel description page 3).

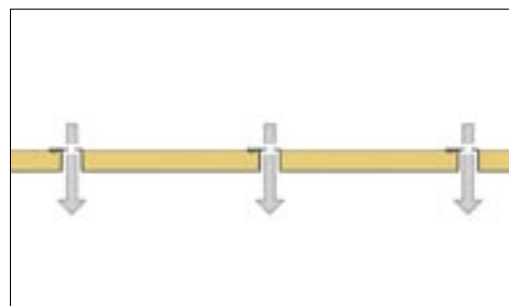

Installation Principles

The Basic Principle - uses Edge Trim No. 13 or DAMPA Top Profiles along the entire perimeter. Suspension hangers and Modular Carrier No. 16 provide the ceiling support.

Suspension hangers and Modular Carrier No. 16 provide the ceiling support.

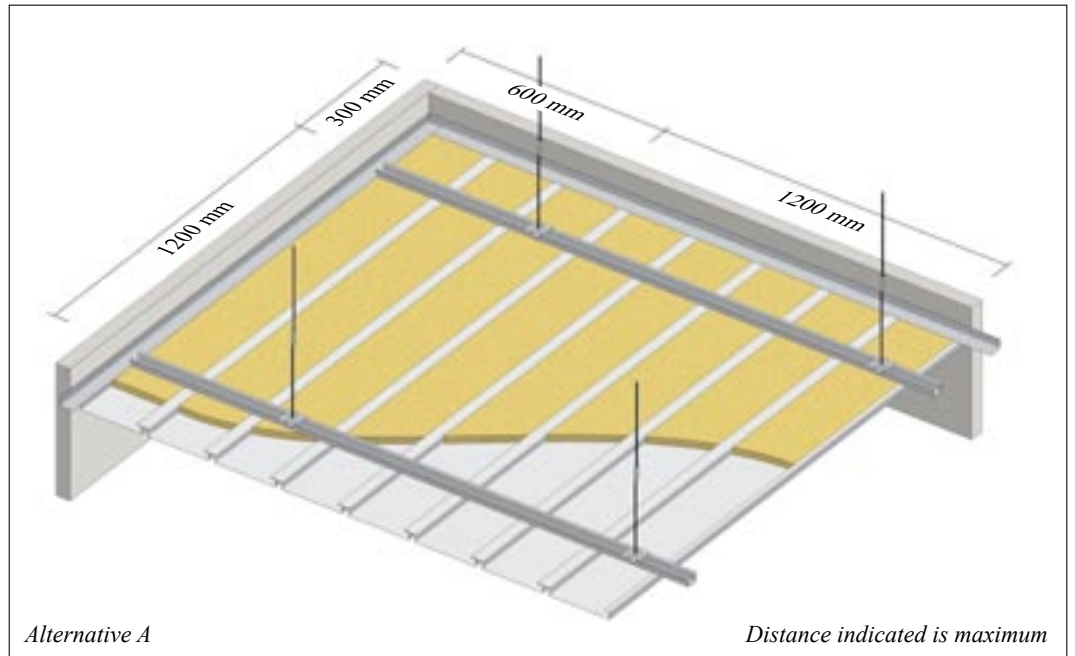

Reduction in Hangers -

can be achieved by providing alternative support at panel ends. This can be obtained by using Angle Runner No. 29 (illustrated), or alternatively Modular Carrier No. 45 secured to DAMPA Top Profiles.

The maximum distance from wall to first carrier can hereby be increased from 300 mm to 1200 mm. Otherwise, the Basic Principle applies.

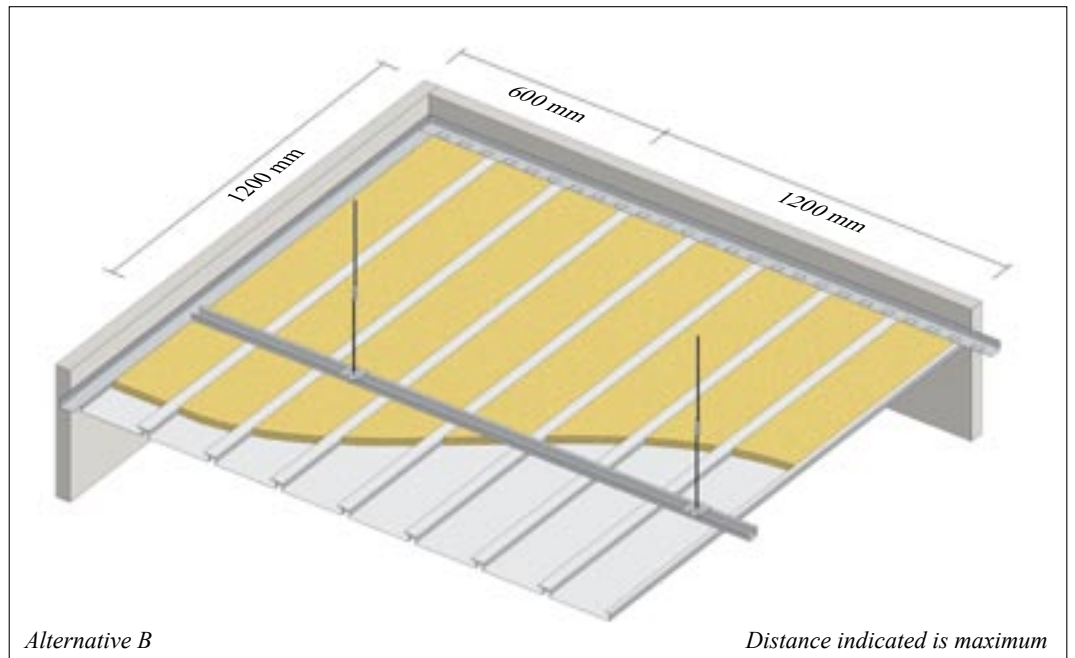

Corridor Ceilings without Hangers -

are possible in areas with widths less than 1250 mm, by using Angle Runner No. 29 (illustrated), or alternatively Modular Carrier No. 45 secured to DAMPA Top Profiles.

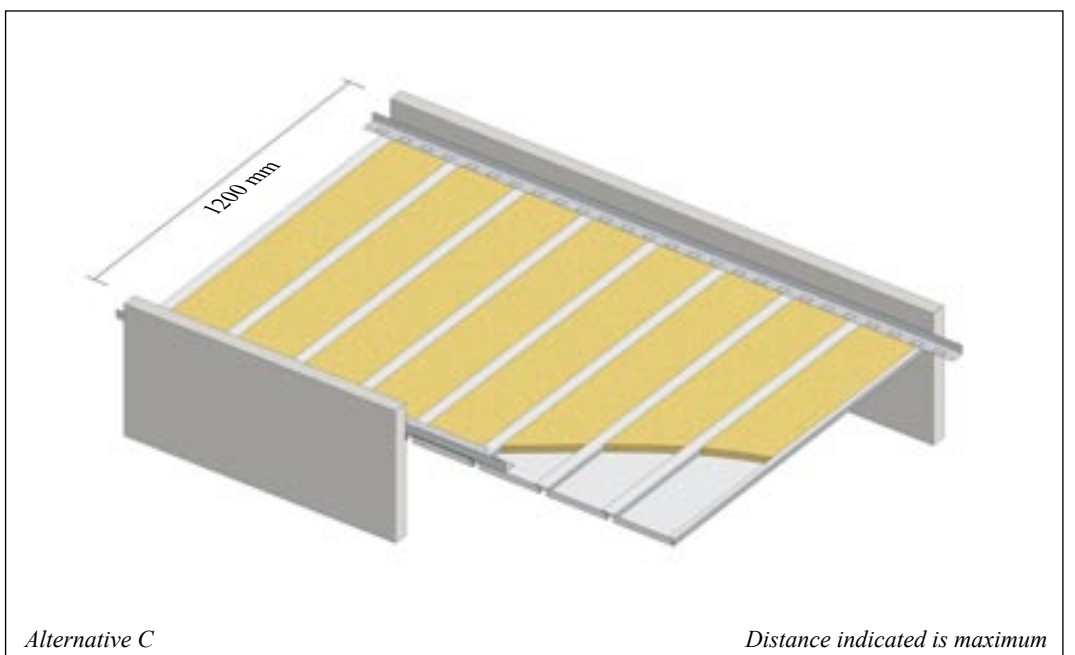

Installation of Suspension Components

Suspension Depth

B-class and C-class ceilings specify no minimum suspension depth.

A-class ceilings require a minimum suspension depth of 300 mm, measured from the top side of the steel deck to the underside of the ceiling panels.

Alignment of Modular Carriers

Modular carriers are run parallel to each other and at 90° to the ceiling panels. The carrier ends are positioned on top of the horizontal flanges of the angle edge trims or top profiles.

Each carrier end is secured to the perimeter with a single steel pop rivet.

Care must be taken to align carrier clips.



Carrier Support

The modular carriers are supported by hangers comprising Suspension No. 1 or No. 3, Rod Clip No. 2 and Threaded Rod M8.

The base plate of Suspension No. 1 or No. 3 is located on top of the modular carrier and locked in position by bending down the two tabs.

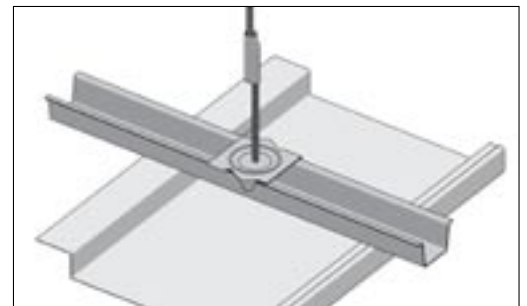

Adjustment of Ceiling Height

The hangers are easily adjusted within a range of approx. 100 mm by varying the thread engagement of the Threaded Rod M8 and Suspension No. 1 or No. 3.

The two engaged threads are securely locked by sliding the Rod Clip No. 2 down until the stop prevents further travel.

Final or minor adjustment of the ceiling level can easily be achieved by lifting Rod Clip No. 2 and altering the thread engagement.

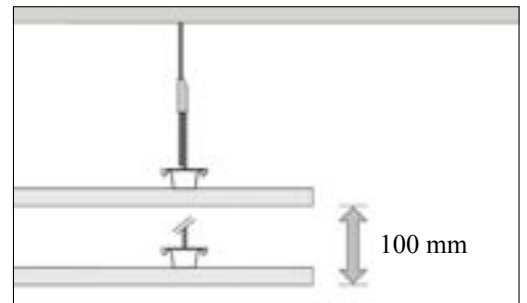

Shock Test

The standard DAMPA DCC 300/200 Ceiling System has, with only minor modification of the Basic Installation Principle, been successfully tested with g forces up to 175 by the Danish and US Navies.

Installation of Ceiling Panels

The DAMPA DCC 300/200 Ceiling Panels are normally installed progressively, starting at either end of the room. However, panels can be left out at any position to be installed later.

After aligning the leading and returned flanges with the clips of the modular carriers, the panels are engaged starting at one end.

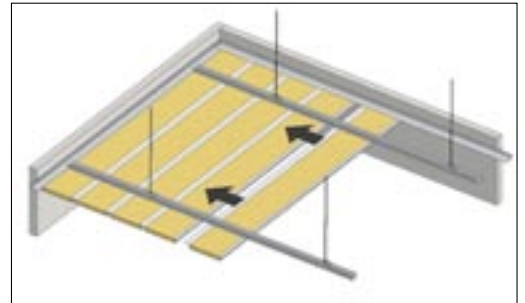
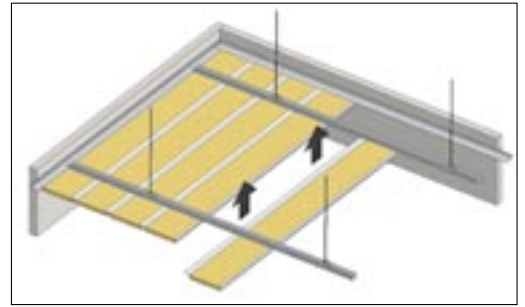

Securing the Panels

Fire rated ceiling panels are installed with a self-tapping screw at each end.

Long panels require an additional screw at every second modular carrier intersection (intervals of approx. 2400 mm).

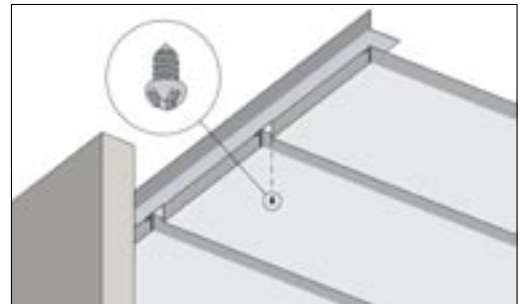

Demounting of Ceiling Panels

Access to the ceiling void can be achieved at any point within the ceiling area, as each panel is individually demountable.

When demounting a ceiling panel, first remove any self-tapping screws and gently release the panel from the carrier, by pulling it towards you and simultaneously pushing the nearest adjacent one. When regular access to the void is required DAMPA recommends incorporating DAMPA Inspection or Access Panels (see illustration page 11).

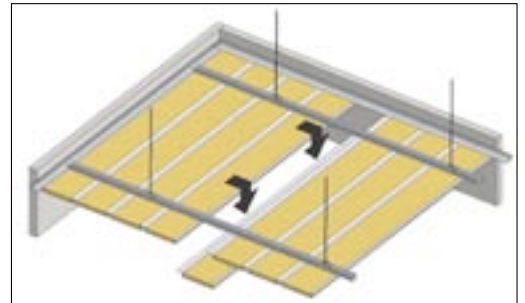

Calculation of Ceiling Panel Lengths

The lengths of the pre-cut ceiling panels are determined by the internal bulkhead-to-bulkhead measurement minus 50 mm. This provides a closed shadow recess of 25 mm along each partition to allow for building tolerances.

For wide rooms and/or to make handling easier, featured joints can be used (see Jointing page 9).

All the advantages of the pre-cut panel concept are maintained.

Shipping and storage: Ceiling panel lengths should not exceed 5700 mm, if standard 20' containers are to be used.

Perimeter Details

DAMPA's perimeter profiles are designed to provide a shadow recess of 25 mm along each partition allowing for building tolerances.

To achieve the 25 mm recess, where top profiles are perpendicular to the modular carriers and are in the direction of the open end of the carrier clips, a 15 mm deep flange cutout at carrier locations is required.

Without this cutout the recess will be 37.5 mm in this position.

If Edge Trim No. 13 is installed in the same position, the 40 mm wide flange should be installed horizontally, whereby flange cutouts are not required.

When ceiling panels have to be cut lengthwise, Edge Trim No. 26 is used. It is pop riveted to the Top Profile flange or Edge Trim No. 13. This will provide a neat finish to the cut edge.

For alternative solution see Factory Modified Panels page 10.

At mitred partitions, or when ceiling panels run at 45°, these are supplied in 'over length' for final cutting on site.

Edge Trim No. 27, together with Clip Inlay No. 3, are used to maintain the alignment of the ceiling panels at the cut edge.

For alternative solution see Factory Modified Panels page 10.

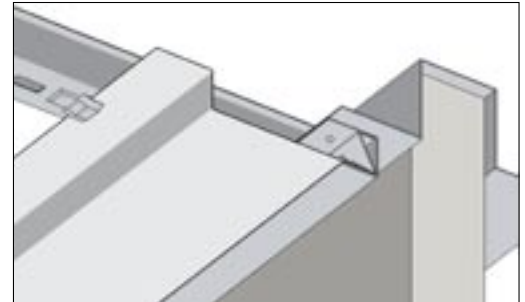
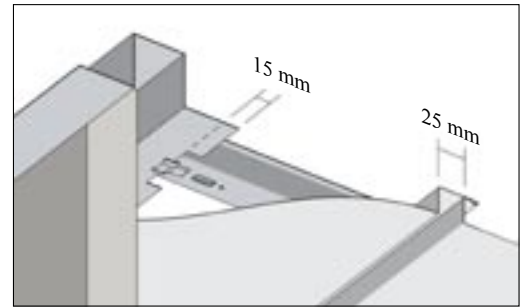

Change in Ceiling Direction

Joining Panels No. 2 and No. 3 can also be used whenever a change in the ceiling direction is required. These panels are particularly suited for corridor crossings.

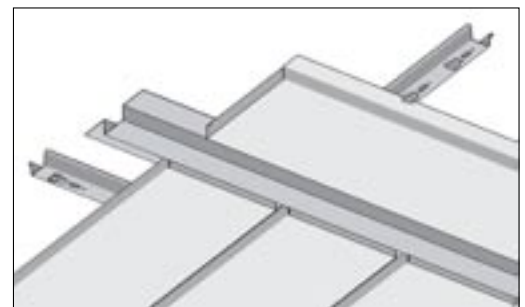

Downstands

Changes in ceiling levels can be achieved in many ways depending on the height of the downstand and the desired visual appearance. The illustration shows a well-proven principle.



Jointing

Joining Panel No. 2

Joining Panel No. 2 creates a 100 mm wide joint consisting of a 50 mm wide strip in the ceiling plane, with 25 mm recesses either side.

The distance from the ceiling panel ends to the first carrier either side of the joining panel must not exceed 50 mm.

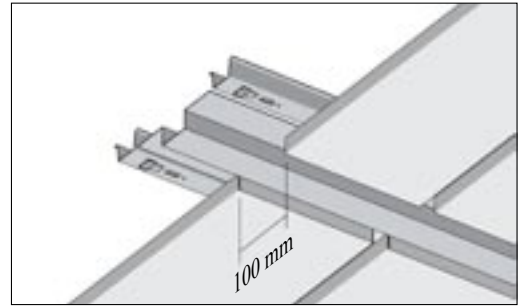

Joining Panel No. 3

In the same way, Joining Panel No. 3 creates a 200 mm wide joint with a 150 mm wide strip.

The distance from the ceiling panel ends to the first carrier either side of the joining panel must not exceed 50 mm.

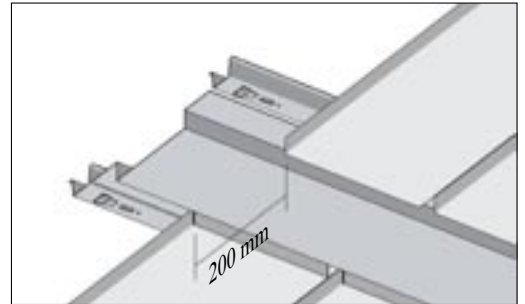

Joining Panel No. 4

For a featured joint with a 25 mm recess between ceiling panel ends, two Modular Carriers No. 16 are fastened to the pre-punched holes in the flat Joining Panel No. 4 using pop rivets 4.0 mm in diameter.

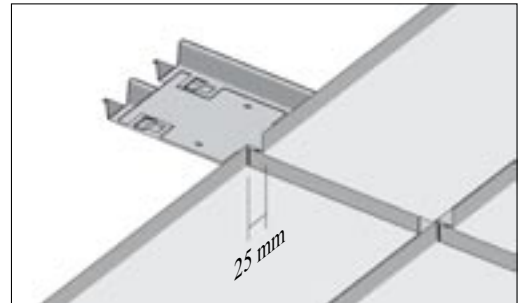

Angle Runners No. 29 Back to Back

This jointing method using Suspension No. 7 will also create a featured joint with a 25 mm recess between the ceiling panels. If desired, offset the back to back Angle Runners No. 29 to one side by 15 mm to prevent the centre joint being visible in the 25 mm recess.

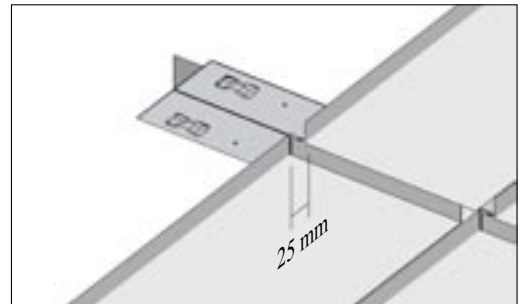

Butt Joint

Staggered butt joints may be used as an alternative to the above.

Please note that under certain lighting conditions butt joints may show slight shadows at the panel ends.

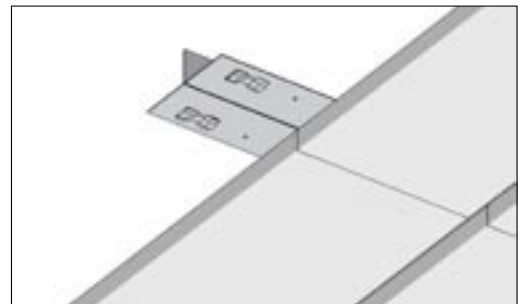

For installations in B-class areas each ceiling panel must be fastened in the recess to the joining panel or angle runners using either screws or steel pop rivets.

Factory Modified Panels

For projects with a large number of identical cabins, Factory Modified Adaption Panels further reduce installation time and costs.

By using these panels Edge Trims No. 26 and No. 27 are no longer needed.

Modified Panels, Type WOF and WF

Start Panels are specially formed narrow ceiling panels without flanges. They are identified by the code WOF.

End Panels are narrow versions of the standard shaped ceiling panel. They are identified by the code WF.

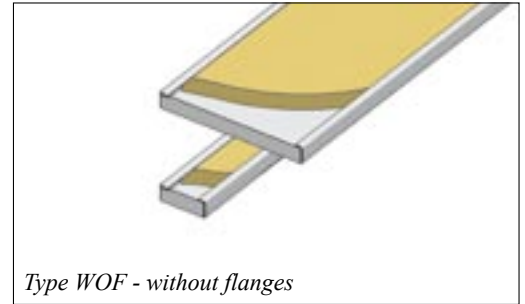

Type WOF - without flanges

Type WOF & WF Ceiling Panels are available in the following widths:

75, 100, 125, 137, 150, 175, 200, 225 and 237 mm.

Other widths can be made to order.

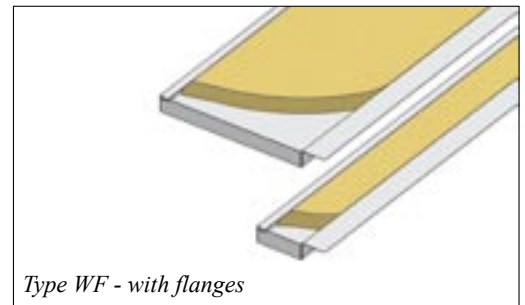

Type WF - with flanges

Clip No. 7

Clip No. 7 pop riveted to Edge Trim No. 13 or to Top Profile (illustrated) is used to secure Adaption Panels type WOF & WF to the perimeter profile parallel to the ceiling panels.

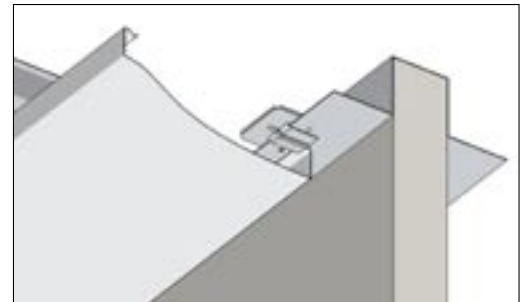

Stepped or Diagonal Ends

Ceiling panels can be supplied with factory-formed stepped or diagonal ends.

Produced to order and specification.

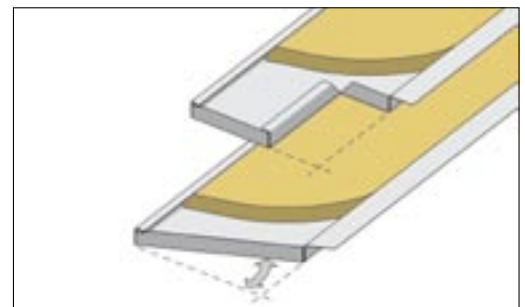

Cutouts

Panels with factory formed cutouts can be supplied to specification.

For example, circular cutouts to suit downlights, speaker grilles and smoke detectors, and rectangular cutouts to suit items such as non-modular luminaires.

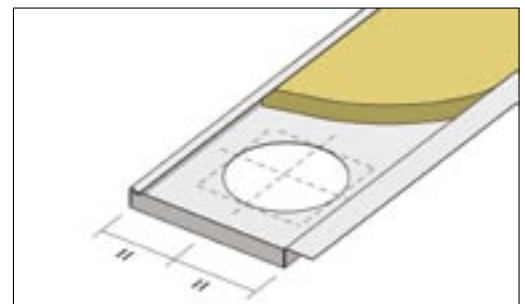

Adapter Panels

For inclusion of ceiling penetrations not specifically designed to integrate with DCC Panels, Adapter Panels can be supplied to specification.

DAMPA Adapter Panels are made unperforated, either painted or in stainless steel, in sizes of 300 x 300, 400 x 400 or 600 x 600 mm.

For large quantities factory formed cutouts are possible, in accordance with customers' drawings.

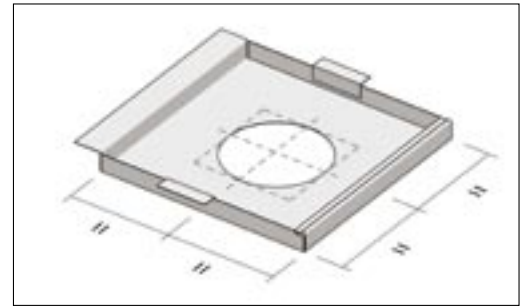

Speaker Grilles

Unperforated ceiling panels can be supplied with speaker grilles, 156 mm in diameter, positioned as required.

The grille consists of a perforated steel plate, 1.8 mm holes at 3.5 mm centres (20.5%) slightly protruding below the surface of the ceiling panel, and covering the cut edge of the hole. It is painted in the ceiling colour shade requested and attached to the ceiling panel with double-sided tape.

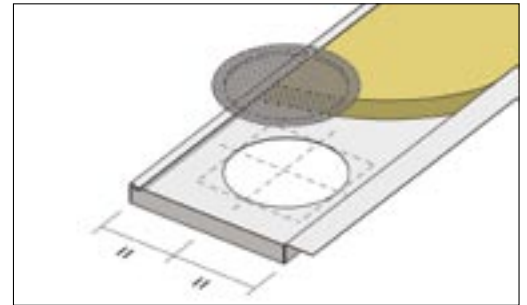

Inspection/ Access Panels

DAMPA Inspection Panels

DAMPA Inspection Panels provide small, easily accessible openings in the DCC 300/200 Ceiling Systems whereby a modified panel is hinged at 90° to the ceiling panel length. Inspection panels are available in lengths from 300 mm to 600 mm.

When ordering, please specify also the required colour and whether perforated or plain.



DAMPA Access Panels

DAMPA Access Panels provide large openings in the DCC 300/200 Ceiling Systems. They are hinged at right angles to the ceiling panel length.

DAMPA Access Panels are available in one standard size, i.e. 600 x 600 mm.

For large quantities other sizes can be made to order.

When ordering, please specify also the required colour and whether perforated or plain.



DAMPA Luminaires

DAMPA Design Integrated Luminaires are available for installation either parallel (illustrated) or at right angles to DCC 300 Ceiling Panels. Physical support of luminaires is provided by the same hanger/carrier system as used for DCC 300 Ceiling Panels.

Pre-positioned luminaires will enable surrounding ceiling panels to be fully pre-cut to accommodate the necessary 'hole' for the luminaires.

Please contact DAMPA for further information.

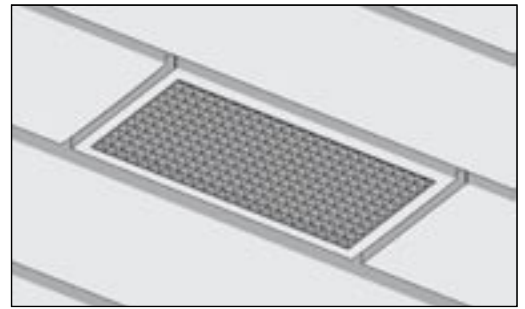

DAMPA Top Profiles

The DCC 300/200 Ceiling Panels are designed to integrate with all types of partitions. DAMPA's range of Top Profiles, illustrated on page 15, are specifically designed to integrate with most of the commonly available partition systems.

DAMPA's Top Profiles are rollformed to tight tolerances to ensure the required precise fit.

Modular Pre-Planning Concept

A Modular Pre-Planning Concept (not illustrated) has been developed to suit rationalised accommodation designs. It is based on a 100 mm modular pre-planning grid, and on all partitions being 50 mm wide and positioned centrally about grid lines.

This concept uses a modular version of the DAMPA Top and Bottom Profiles to suit 50 mm partitions, including all necessary straight, tee and corner splices.

Start and End Adaption Panels are also included.

Colours and Surfaces

The DCC 300/200 Ceiling Panels are stove-enamelled with non-toxic polyester paint prior to rollforming, resulting in a superior finish and excellent durability.

Standard Colour White

DAMPA's standard colour is:
NCS 1003-B82G White matt No. 3000-2.

Special Colours

Almost any colour shade is available on request in the following gloss levels (at 60°), designated by code numbers 1, 2 or 5:

xxx-1, gloss 80 +/- 5

xxx-2, matt 10 +/- 2

xxx-5, anti-reflection/textura 0-5

(by DAMPA for wheelhouse ceilings).

Special colour requests will be converted to the nearest NCS (Natural Colour System) colour code.

Car Deck Paint

DCC 300 Type 308 is on request available in a special white car deck paint finish, developed to withstand high humidity and car exhaust fumes.

Brushed Stainless Steel

DCC 300 Type 308 is available in 0.5 mm Brushed stainless steel; quality AISI 304, grain size 220, for use in galleys, laundries, etc.

Mirror Finished Stainless Steel

DCC 200 Type 208 is available in 0.5 mm Mirror Finished stainless steel.

This product is primarily used for decorative purposes.

Stainless Steel Edge Trims and Joining Panels

Edge Trims No. 13, 26 and 27 and Joining Panels No. 2 and 3 are available in both Brushed and Mirror Finished stainless steel.

Please note that these items are supplied in a thickness of 0.5 mm and in 2000 mm length (Joining Panels in 3000 mm).

Standard Packaging

Ceiling Panels

The DCC 300/200 Ceiling Panels are supplied in standardised, rigid non returnable cardboard boxes easy to stack for optimum handling and storage. Standard boxes, of varying lengths to suit ceiling panels, normally contain 8 pieces of DCC 300 or 11 pieces of DCC 200 Ceiling Panels.

Methods of packing may vary slightly between the different DAMPA production centres.

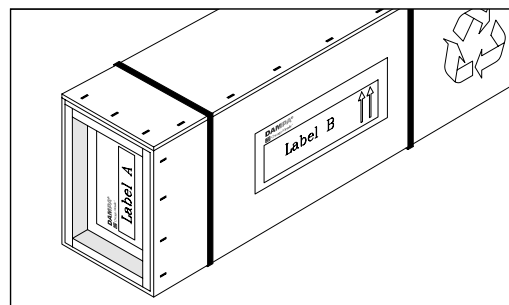

Environmentally friendly recyclable packaging materials.

Accessories

Small suspension components such as Rod Clip No. 2, Suspension No. 1, etc. and stove-enamelled items such as edge trims are supplied in standard cardboard boxes.

Modular carriers, top and bottom profiles, threaded rods, etc. are supplied palletted in bundles.

Truck Delivery/Containerised Shipment

All materials are packed to suit both truck delivery and containerised shipment.

Please note that the maximum ceiling panel length that can be accommodated in a 20' container is 5700 mm.

Marking and Labelling Concept

All information required for easy identification and efficient handling of ceiling panel boxes can be found on the large labels, which are glued to the box side and the box end cover.

The labels provide information such as deck and room numbers and box contents.

DAMPA's new Computerised Marking and Labelling Concept can provide a variety of information to suit specific needs.

Please contact DAMPA for further information.

Fast Reliable Delivery

Fast and reliable delivery is a trademark of DAMPA's modern and flexible production facilities situated with easy access to the

European highway system and close to main ports for international shipping.

Quality Assurance

All DAMPA Marine Ceiling Systems are manufactured to high standards within close tolerances to ensure accurate, fast and reliable installation.

The DAMPA Marine Ceiling Systems are produced to DAMPA's Quality Management System approved by Lloyd's Register in accordance with ISO 9001:2000.

References

The trust in DAMPA products and expertise is proudly reflected in more than 3,000 shipbuilding projects of all types, totalling more than 4.5 million square metres of DCC 300/200 Ceiling.

Of these references more than 400 relate to some of the latest and most prestigious passenger vessels and cruise liners.

Engineering Expertise

DAMPA has accumulated more than 30 years of experience within all types of international projects. With this experience DAMPA can offer expert assistance with the preparation of ceiling layout drawings and material take-

offs. Drawing exchange is normally based on AutoCAD's DWG format or the universal drawing exchange format DXF.

Basic Installation Components

Threaded Rod M8
 Diameter : 8 mm
 Length : 200, 300, 400, 500, 600 and 2000 mm
 Weight : 0.30 kg/lin.m
 Material : Galvanised steel



Modular Carrier No. 16
 Height : 27 mm
 Width : 51 mm
 Length : 4000 mm
 Weight : 0.75 kg/lin.m
 Material : Galvanised steel

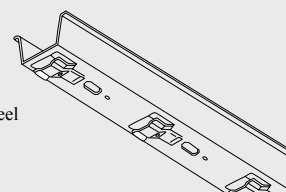

Rod Clip No. 2
 Total length: 50 mm
 Weight : 0.015 kg/each
 Material : Galvanised steel



Runner Splice No. 12
 Height : 20 mm
 Width : 36 mm
 Length : 321 mm
 Weight : 0.15 kg/each
 Material : Galvanised steel

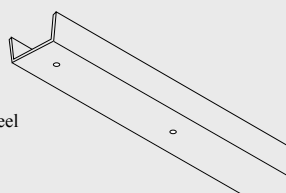

Suspension No. 1
 Total height: 150 mm
 Weight : 0.05 kg/each
 Material : Galvanised steel

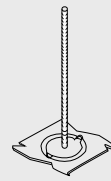

Edge Trim No. 13
 Height : 40 mm
 Width : 55 mm
 Length : 4000 mm
 Weight : 0.80 kg/lin.m
 Material : 1.0 mm galvanised steel, stove-enamelled
 Colour to be stated

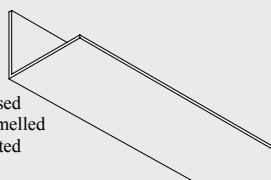

Optional Installation Components

Suspension No. 3
 Vibration absorbing suspension
 Total height: 150 mm
 Weight : 0.05 kg/each
 Material : Galvanised steel with rubber bush

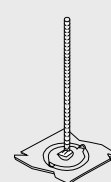

Modular Carrier No. 45
 Height : 3 mm
 Width : 70 mm
 Length : 3000 mm
 Weight : 0.90 kg/lin.m
 Material : Galvanised steel

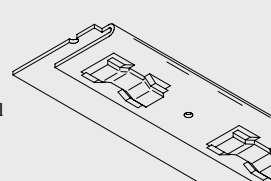

Angle Runner No. 29
 Height : 40 mm
 Width : 64 mm
 Length : 4000 mm
 Weight : 1.05 kg/lin.m
 Material : 1.0 mm galvanised steel, stove-enamelled
 Colour to be stated

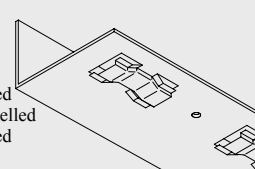

Edge Trims and Joining Panels

Edge Trim No. 26
 Height : 27 mm
 Width : 25 mm
 Length : 4000 mm
 Weight : 0.80 kg/lin.m
 Material : 1.0 mm galvanised steel, stove-enamelled
 Colour to be stated

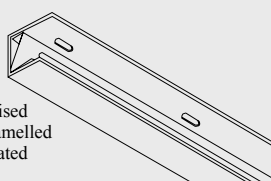

Joining Panel No. 2
 Height : 29 mm
 Width : 55 + 50 + 55 mm
 Length : 3000 mm
 Weight : 1.05 kg/lin.m
 Material : 0.6 mm galvanised steel, stove-enamelled
 Colour to be stated

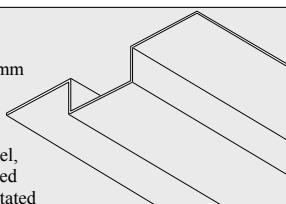

Edge Trim No. 27
 Height : 27 mm
 Width : 25 mm
 Length : 4000 mm
 Weight : 0.65 kg/lin.m
 Material : 1.0 mm galvanised steel, stove-enamelled
 Colour to be stated

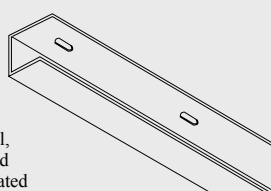

Joining Panel No. 3
 Height : 29 mm
 Width : 55 + 150 + 55 mm
 Length : 3000 mm
 Weight : 1.45 kg/lin.m
 Material : 0.6 mm galvanised steel, stove-enamelled
 Colour to be stated

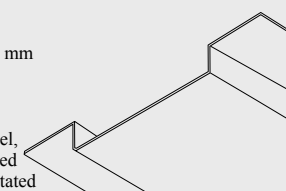

Clip Inlay No. 3
 Height : 25.5 mm
 Width : 24.5 mm
 Length : 2000 mm
 Weight : 0.15 kg/lin.m
 Material : 0.3 mm galvanised steel

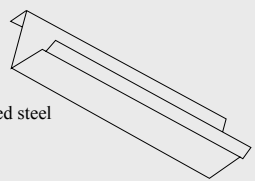

Joining Panel No. 4
 Thickness : 0.6 mm
 Width : 110 mm
 Length : 2000 mm
 Weight : 0.85 kg/lin.m
 Material : Galvanised steel, stove-enamelled
 Colour to be stated

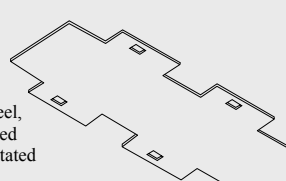

Accessories

Inspection Panel
 Module : 300/200 mm
 Length : 300 to 600 mm
 Material : Galvanised steel,
 stove-enamelled
 Colour to be stated

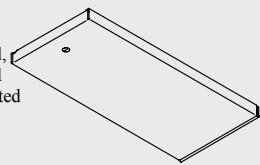

Access Panel
 Module : 2 x 300/200 mm
 Length : 600/400 mm
 Material : Galvanised steel,
 stove-enamelled
 Colour to be stated

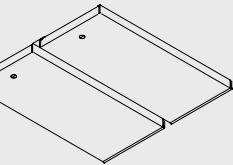

Adapter Panel
 Height : 26 mm
 Size : 300 x 300 mm
 400 x 400 mm
 600 x 600 mm
 Material : Galvanised steel,
 stove-enamelled
 Colour to be stated

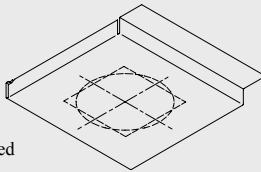

Factory Integrated Speaker Grille
 Diameter : 156 mm
 Material : Galvanised steel,
 stove-enamelled
 in ceiling colour.
 Applicable for
 module 300/200 panels
 Length : 300 to 5000 mm positioned as requested

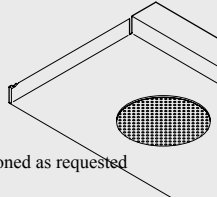

Suspension Profile No. 1
 Height : 13 mm
 Width : 47 mm
 Length : 4000 mm
 Weight : 0.60 kg/lin.m
 Material : 1.0 mm galvanised steel

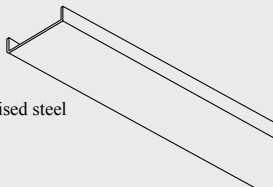
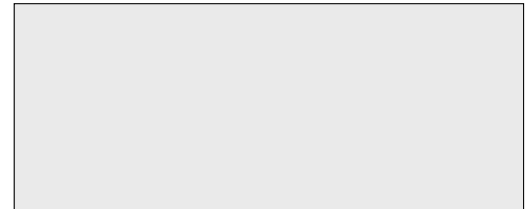
Additional insulation for B-15/A-60 class
 Separately delivered in 600 x 1000 mm batts

Type	Min. wool	Firebatts	Firebatts
Thickness	: 50 mm	25 mm	35 mm
Weight/sq.m	: 1.6 kg	2.7 kg	3.8 kg
Fire classification	: B-15/A-60	B-15/A-60	B-30

Miscellaneous
 Screw No. 8 - for securing ceiling panels
 Clip No. 7 - for securing type WOF and WF Panels
 Touch-Up Paint - 1 litre cans, incl. hardener/thinner
 Perimeter Finish: Felt No. 3 - 2 x 20 mm x 15 m
 Felt No. 4 - 1 x 55 mm x 25 m

Top/Bottom Profiles

Top Profile No. 13
 Height : 52 mm
 Width : 55 + 50 + 55 mm
 Length : 3900 mm
 Weight : 2.05 kg/lin.m
 Material : 1.0 mm
 galvanised steel,
 stove-enamelled, black

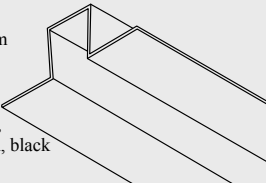

Top Profile No. 17
 Height : 52 mm
 Width : 55 + 25 + 55 mm
 Length : 3900 mm
 Weight : 1.85 kg/lin.m
 Material : 1.0 mm
 galvanised steel,
 stove-enamelled, black

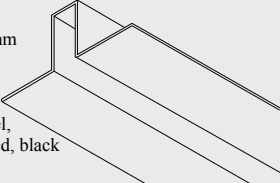

Top Profile No. 14
 Height : 52 mm
 Width : 55 + 50 + 9 mm
 Length : 3900 mm
 Weight : 1.70 kg/lin.m
 Material : 1.0 mm
 galvanised steel,
 stove-enamelled, black

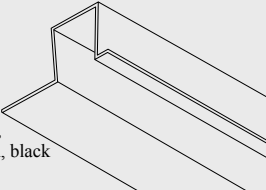

Top Profile No. 18
 Height : 52 mm
 Width : 55 + 25 + 9 mm
 Length : 3900 mm
 Weight : 1.50 kg/lin.m
 Material : 1.0 mm
 galvanised steel,
 stove-enamelled, black

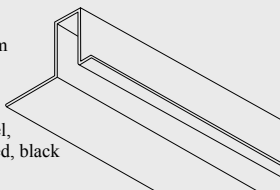

Top Profile No. 15
 Height : 28 mm
 Width : 55 + 50 + 55 mm
 Length : 3900 mm
 Weight : 1.70 kg/lin.m
 Material : 1.0 mm galvanised
 steel, stove-enamelled,
 black

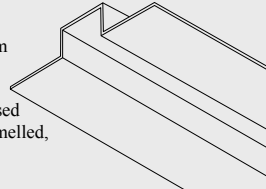

Top Profile No. 19
 Height : 28 mm
 Width : 55 + 25 + 55 mm
 Length : 3900 mm
 Weight : 1.45 kg/lin.m
 Material : 1.0 mm
 galvanised steel,
 stove-enamelled, black

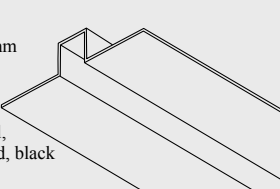

Top Profile No. 16
 Height : 28 mm
 Width : 55 + 50 + 9 mm
 Length : 3900 mm
 Weight : 1.30 kg/lin.m
 Material : 1.0 mm galvanised
 steel, stove-enamelled,
 black

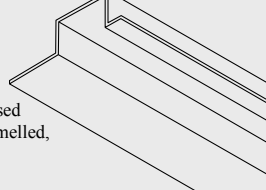

Top Profile No. 20
 Height : 28 mm
 Width : 55 + 25 + 9 mm
 Length : 3900 mm
 Weight : 1.10 kg/lin.m
 Material : 1.0 mm galvanised
 steel, stove-enamelled,
 black

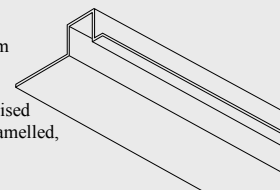

Bottom Profile No. 10
 Height : 27 mm
 Width : 50 mm
 Length : 3900 mm
 Weight : 0.85 kg/lin.m
 Material : 1.0 mm galvanised steel

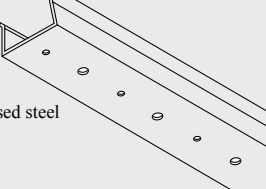

Bottom Profile No. 15
 Height : 27 mm
 Width : 25 mm
 Length : 3900 mm
 Weight : 0.60 kg/lin.m
 Material : 1.0 mm galvanised steel

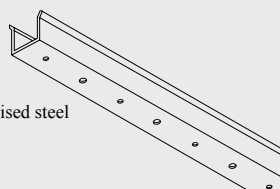



DAMPA®

Marine Ceiling Systems

DAMPA, DK-5690 Tommerup

Phone: +45 63 76 13 20, fax: +45 63 76 13 99, e-mail: dampa@dampa.dk, www.dampa.com

A member of the Chicago Metallic group of companies